

news 02

jumbolino

← Available now →

DCW - TCW

In our continuous effort to improve the technology of our winding machines Metar is pleased to inform you that DCW (Dual Concentric Winding) and TCW (Triple Concentric Winding) is now available on Jumbolino winder.

- ariane
- pallas
- metronic
- monostar
- jumbolino**
- sigma
- twincap

Star connection

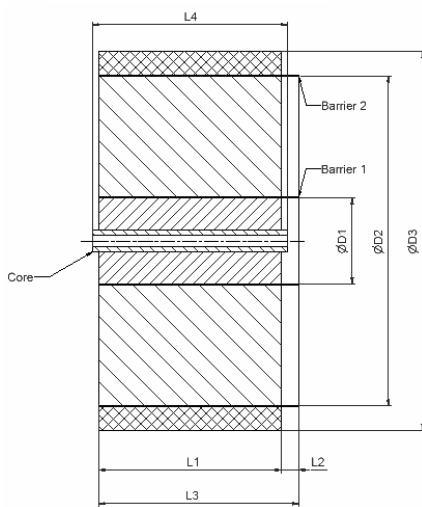

Delta connection

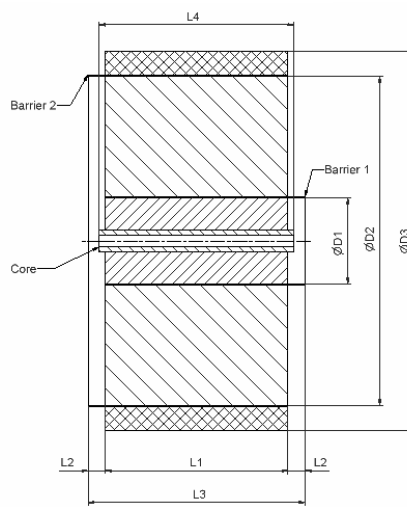

ØD1; ØD2	Ø Barrier	35 to 130 mm
ØD3	Ø Winding	max. 155 mm
L1	Winding width	37.5 to 158 mm
L2	Barrier shift	2 to 7 mm
L3		max. 158 mm
L4	Core	40 to 160 mm

<i>Barrier film :</i>	
Ø max. :	250 mm
Ø core :	75 (3") mm
Film thickness :	30 - 100 µm
Film width :	40 - 158 mm

DCW

TCW

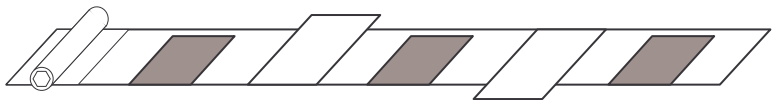
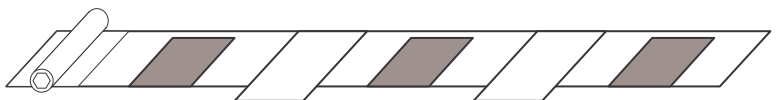

For more information please contact us at