



automatic Li-Ion cells winding machine

# GREENCAP

Producing high quality round and prismatic cells



Fields of application



Worldwide leader in the manufacturing of :

# METAR machines

- ▶ winding machines for capacitors, ultra-capacitors and Li-Ion cells
- ▶ assembly lines for capacitors and ultra-capacitors

# Product

## ▶ Cell Dimensions

|                  |        |
|------------------|--------|
| Minimum diameter | 18 mm  |
| Maximum diameter | 155 mm |
| Minimum Width    | 66 mm  |
| Maximum Width    | 158 mm |

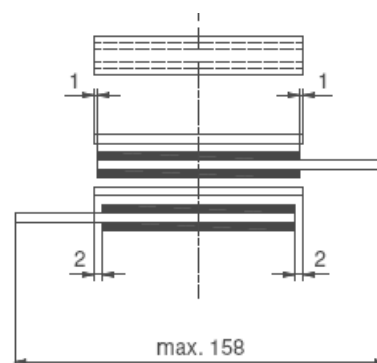

## ▶ Core Dimensions

|                    |        |
|--------------------|--------|
| Minimum length [H] | 66 mm  |
| Maximum length [H] | 160 mm |

### ▶ Hexagonal shape

|              |      |
|--------------|------|
| Hex min. [d] | 4mm  |
| Hex max. [d] | 13mm |
| OD min. [D]  | 6mm  |
| OD max. [D]  | 20mm |

### ▶ Round shape

|             |        |
|-------------|--------|
| ID min. [d] | 22mm   |
| ID max. [d] | 46mm   |
| OD min. [D] | 23.5mm |
| OD max. [D] | 48mm   |

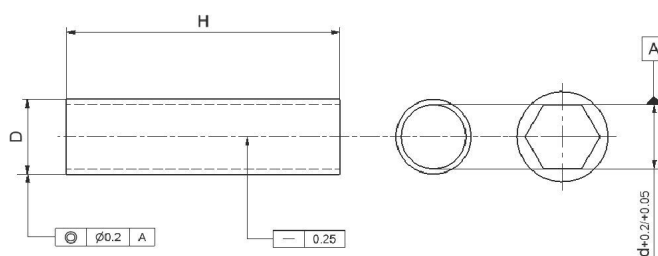

# Contacts

**Head office**  
**Metar SA**  
Route de Montena 79  
1728 Rossens  
Switzerland  
Phone +41 26 407 38 38  
Fax +41 26 407 38 39  
e-mail [office@metar-machines.com](mailto:office@metar-machines.com)  
<http://www.metar-machines.com>

**China**  
**Metar SA Beijing Office**  
Room C1205  
Jin Yu International Mansion  
No 48, West Wuangjing Road  
Chaoyang District, Beijing China  
Phone +86 10 64 78 73 74  
Fax +86 10 64 78 75 74  
e-mail [houl-yl@vip.sina.com](mailto:houl-yl@vip.sina.com)